

# Bendi®



## ***BENDI DEEP REACH***

### ***B40AC-DR & B50AC-DR***

#### **4-WHEEL HIGH LIFT BENDI**

#### **ELECTRIC MULTI-PURPOSE VNA**

#### **ARTICULATED FORKLIFT TRUCK**

#### ***STANDARD FEATURES***

- Four Wheel Design, Dual Rear Wheel Drive
- 8" (200 mm) Stroke Integral Side Shifter
- 41" (1041 mm) Stroke Integral Pantograph Reach
- 52" (1321 mm) Reach From Face of Mast
- 33" (838 mm) Wide Tilting and Side Shifting Fork Carriage
- Adjustable Seat and Steering Wheel
- Rotation via DuraSteer™ Actuator, with 5-Year Warranty on Articulation
- Dual Curtis AC Traction Motor Controllers
- Curtis AC Hydraulic Motor Controller
- Battery Discharge Indicator with Slow Alert
- Hydraulic Disk Brakes
- "Floating" Articulated Front Axle
- One Parts and Operator's Manual Included
- Curtis Engage Dash Display
- Hand Actuated Parking Brake
- 36" (914mm) High Backrest
- High Visibility Mast
- 170° Rear View Mirror
- Safety Seat Switch and Seat Belt
- Fixed Mast with Carriage Tilt of 3° Fwd / 4° Rwd
- 48 Volt Electrical System
- Three Section Hydraulic Control Valve
- Smooth Rubber Drive Tires
- Soft Polyurethane Load Wheel Tires
- 40" Tapered Tip Forks - Rear Tow Hitch Pin
- Meets ANSI B56.1

#### ***OPTIONAL FEATURES***

- Non-Standard Fork Lengths
- LED Headlights, Flashing Light and Rear Safety Lights
- Non-Marking Tires
- Vinyl Seat
- Slide-Out Sideways Battery Tray
- Fire Extinguisher
- Lazer Fork Height Indicator
- Carriage Mounted Camera with Operator Compartment Monitor
- Capable of Freezer Operation to -22°F (-30°C)



# **LANDOLL CORPORATION**

**MATERIAL HANDLING GROUP**

**1900 North Street | Marysville, KS 66508**  
**(800) 428-5655 | [www.landoll.com/mhp](http://www.landoll.com/mhp)**



# BENDI DEEP REACH B40AC-DR & B50AC-DR

## Electric Multi-Purpose VNA | Articulated Forklift Truck

### TECHNICAL DATA

MODEL			B40AC-DR	B50AC-DR
Capacity		lbs/kg	2,500 / 1,136	3,000 / 1,364
Load Center		in/mm	24 / 600	24 / 600
Power Source			Battery, Electric	Battery, Electric
Weight with Battery		lbs/kg	14,270 / 6,486	17,350 / 7,886
Travel Speed	Loaded	mph/kph	6.5 / 10.5	6.5 / 10.5
	Unloaded	mph/kph	7 / 11.3	7 / 11.3
Lift Speed	Loaded	fpm/mpm	90 / 27.4	90 / 27.4
	Unloaded	fpm/mpm	110 / 33.4	110 / 33.4
Lowering Speed	Loaded	fpm/mpm	100 / 30.5	100 / 30.5
	Unloaded	fpm/mpm	90 / 27.4	90 / 27.4
Carriage Tilt		Fwd / Back deg	3 / 4	3 / 4
Lost Load Center	E	in/mm	21 / 533.4	21 / 533.4
Lost Load Center Extended	E*	in/mm	61 / 1,549.4	61 / 1,549.4
Wheelbase	F	in/mm	72.6 / 1,844	72.6 / 1,844
Rear Overhang	G	in/mm	28.6 / 726	31.6 / 803
Overall Length to Face of Forks	H	in/mm	122.2 / 3,103.9	125.2 / 3,180
Underclearance	I	in/mm	3 / 76	3 / 76
Cab Floor Height	J	in/mm	31.3 / 795	31.3 / 795
Seat Height	K	in/mm	52 / 1,321	52 / 1,321
Overhead Guard Height	L	in/mm	89 / 2,261	89 / 2,261
Chassis Width	M	in/mm	50 / 1,270	56 / 1,422.4
Battery Compartment Height	N	in/mm	19.24 / 489	19.24 / 489
Fork Length	O	in/mm	40 / 1,016	40 / 1,016
Front Articulation	P	deg	180	180
Front Axle Width		in/mm	48 / 1,219.2	48 / 1,219.2
Gradeability	Unloaded	%	15	15
	Loaded	%	15	15
Hydraulic Motor Rating	Continuous Duty	kW	12	12
Drive Motor Rating	Continuous Duty	kW	2 x 5.6 11.2 Total	2 x 7.5 15 Total
Wheel Sizes	Front (1 each)	in/mm	14x5 / 356x127	14x5 / 356x127
	Rear (2 each)	in/mm	18x7 / 457x178	18x9 / 457x229
Traction Control Type	Curtis		AC	AC
Hydraulic Control Type	Curtis		AC	AC

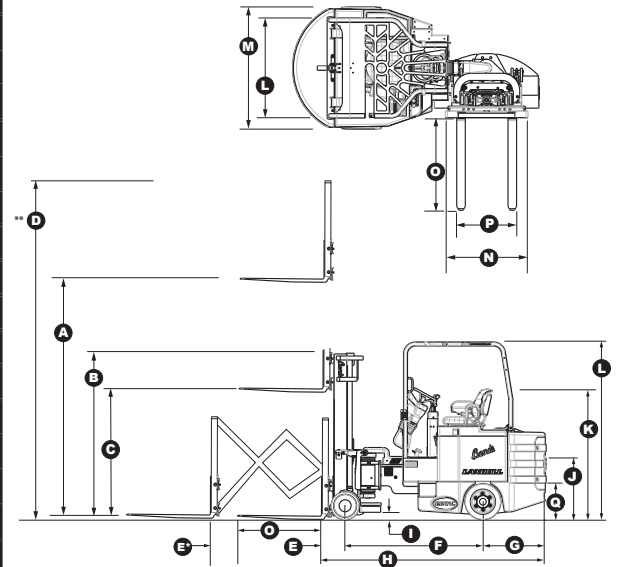

### AISLE DIMENSIONS

B40AC-DR	
LOAD DEPTH X WIDTH (Q x R)	MINIMUM CLEAR AISLE
40" x 48" (1,000 x 1,200mm)	96" (2,438mm)
48" x 40" (1,200 x 1,000mm)	96" (2,438mm)
Minimum Clear Transfer Aisle	119" (3,023mm)
B50AC-DR	
LOAD DEPTH X WIDTH (Q x R)	MINIMUM CLEAR AISLE
40" x 48" (1,000 x 1,200mm)	96" (2,438mm)
48" x 40" (1,200 x 1,000mm)	96" (2,438mm)
Minimum Clear Transfer Aisle	122" (3,099mm)

### RECOMMENDED BATTERY

BATTERY FOR B40AC-DR	
Battery Designation: 24-A85-21, 48 Volt, 850 AHC (6 Hour Rate)	
Nominal size: 32.75" x 38.125" x 22.63" (83 x 97 x 57cm)	
Truck compartment size: 33.25" x 38.875" x 23" (84 x 99 x 59cm)	
Battery Weight: Min 3,250 lbs. (1,477kg) - Max 3,400 lbs. (1,545kg)	
Leads are at Position A, 12" Long, with SB 350 Amp Blue Connector	
BATTERY FOR B50AC-DR	
Battery Designation: 24-85-23, 48 Volt, 935 AHC (6 Hour Rate)	
Nominal Size to 32.25" x 44.75" x 22.63" (82 x 114 x 58cm)	
Truck Compartment size to 32.5" x 44.875" x 23" (83 x 114 x 59cm)	
Battery Weight: Min. 3,500 lbs. (1,590kg) - Max. 4,000 lbs. (1,818kg)	
Leads are at Position A, 12" Long, with SB 350 Amp Blue Connector	

### MAST DIMENSIONS

LIFT HEIGHT (A)		LOWERED HEIGHT (B)		*FREE LIFT (C)		OVERALL HEIGHT (D)	
Inches	Meters	Inches	Meters	Inches	Meters	Inches	Meters
198	5.03	89	2.26	53	1.35	235	5.97
210	5.33	95	2.41	59	1.50	247	6.27
240	6.10	107	2.72	71	1.80	277	7.04
258	6.55	113	2.87	77	1.96	295	7.50
270	6.86	119	3.02	83	2.11	307	7.80
300	7.62	131	3.33	95	2.41	337	8.56
330	8.38	149	3.78	113	2.87	367	9.32
366	9.30	161	4.09	125	3.18	413	10.49
390	9.91	169	4.29	133	3.38	427	10.85
425	10.80	191	4.85	155	3.94	462	11.73

The specifications contained in this spec sheet are subject to change at any time without notice. Actual dimensions and performance data given herein may vary due to manufacturing tolerances.

