



Bendi

BENDI B40VAC

4-WHEEL HEAVY CAPACITY ELECTRIC MULTI-PURPOSE ARTICULATED FORKLIFT TRUCK

The Landoll Bendi B40VAC is a 4-wheel articulating forklift maximizing cube utilization while providing front loader versatility. Increased productivity, operator comfort and safety are the primary benefits.

FEATURES

- 4,000 lb. (1,814kg) Capacity
- Lift Heights to 360" (9.14M)
- 72" (1.82M) Stacking Aisle
- 9.75" (248mm) Sideshifter and 36" (914mm) High Load Backrest Standard
- 32" (813mm) Wide Front Axle
- Dual Inside / Outside Capability
- AC Powered
- Optional Cold Storage Conditioned to -22°F (-30°C)

DRIVE TRAIN

- Large Diameter Smooth Rubber Drive Tires
- Polyurethane Load Tires
- 180° Front-End Articulation / Steering
- Heavy Duty Dual Rear Wheel Planetary Drives
- Powerful Drive and Hydraulic Motors

ENGINEERING

- Forward and Rearward Mast Tilt
- Heavy Duty Chassis Design
- Rotation Via Dual Taper Roller Bearings with 3-Year Warranty on Articulation
- Full Diagnostics Dash Display
- Easily Accessible Components for Low Cost Maintenance

ERGONOMICS & SAFETY

- Hydraulic Power Steering
- Comfortable Seated Operation with All Truck Controls in Easy Reach
- 4-Post Heavy Duty Overhead Guard
- Safety Deadman Seat Switch
- Clearview 3-Stage Mast
- Key Switch, Horn, Hour Meter, Adjustable Suspension Seat and Steering Column, Seat Belt and Armrest are Standard

ELECTRICAL

- AC Powered Dual Traction Motor Controller
- AC Powered Hydraulic Pump Motor Controller
- Battery Discharge Indicator with Lift Interrupt
- Lighting and Alarm Accessories Available
- Provisions for RF Terminals Provided



LANDOLL CORPORATION

MATERIAL HANDLING PRODUCTS

www.landoll.com/mhp



BENDI B40VAC

Electric Multi-Purpose VNA | Articulated Forklift Truck

TECHNICAL DATA

MODEL		B40VAC	
Capacity		lbs/kg	4,000 / 1,814
Load Center		in/mm	24 / 600
Power Source			Battery, Electric
Weight with Battery		lbs/kg	13,770 / 6,259
Travel Speed	Loaded	mph/kph	6.5 / 10.5
	Unloaded	mph/kph	7 / 11.3
Lift Speed	Loaded	fpm/mpm	90 / 27.4
	Unloaded	fpm/mpm	110 / 33.5
Lowering Speed	Loaded	fpm/mpm	100 / 30.5
	Unloaded	fpm/mpm	90 / 27.4
Mast Tilt	Fwd / Back	deg	1 / 2
Lost Load Center	a	in/mm	9.2 / 233.7
Wheelbase	b	in/mm	62.2 / 1,579.9
Overall Length to Face of Forks	c	in/mm	100.1 / 2,542.5
Underclearance	d	in/mm	3 / 76
Cab Floor Height	e	in/mm	31 / 787
Seat Height	f	in/mm	51 / 1,295
Overhead Guard Height	g	in/mm	87 / 2,209
Chassis Width	h	in/mm	48 / 1,219
Gradeability	Unloaded	%	15
	Loaded	%	15
Hydraulic Motor Rating (AC)		kWh	12
Drive Motor Rating (AC)	Dual rear	kWh	5.6 ea - 11.2 Total
Wheel Sizes	Front (2 Each)	in/mm	12x5 / 305x127
	Rear (2 Each)	in/mm	18x7 / 457x178
Traction Control Type			AC
Front Articulation	m	deg	180

MAST DIMENSIONS

LIFT HEIGHT		LOWERED HEIGHT		FREE LIFT	
Inches	Meters	Inches	Meters	Inches	Meters
156	3.96	92	2.34	56	1.42
204	5.18	108	2.74	72	1.83
222	5.64	120	3.05	84	2.13
250	6.35	139	3.53	103	2.62
272	6.91	154	3.91	118	3.00
288	7.32	161	4.09	125	3.18
312	7.92	178	4.52	142	3.61
360	9.14	199	5.05	163	4.14

AISLE DIMENSIONS

LOAD DEPTH X WIDTH (j x i)	MINIMUM CLEAR AISLE
40" x 48" (1,000 x 1,200mm)	66" (1,676mm)
48" x 40" (1,200 x 1,000mm)	72" (1,828mm)
Minimum Clear Transfer Aisle	108" (2,743mm)

RECOMMENDED BATTERY

BATTERY DESIGNATION: 24-85-19, 48 VOLT, 765 AHC (6 HOUR RATE)
Nominal Size: 25.9375" x 44.5625" x 22.625" (66 x 113 x 58cm)
Truck Compartment Size: 26" x 44.75" x 23" (66 x 114 x 58cm)
Battery Weight: Min. 2,600 lbs. (1,181kg) - Max. 3,100 lbs. (1,409kg)
Leads are at Position A, 12" (30.5cm) Long, with SB 350 Amp Blue Connector

The specifications contained in this spec sheet are subject to change at any time without notice. Actual dimensions and performance data given herein may vary due to manufacturing tolerances.

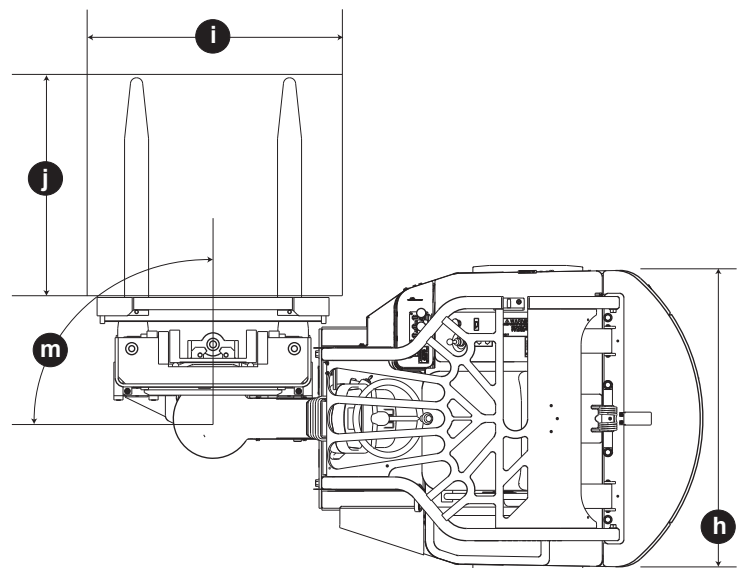
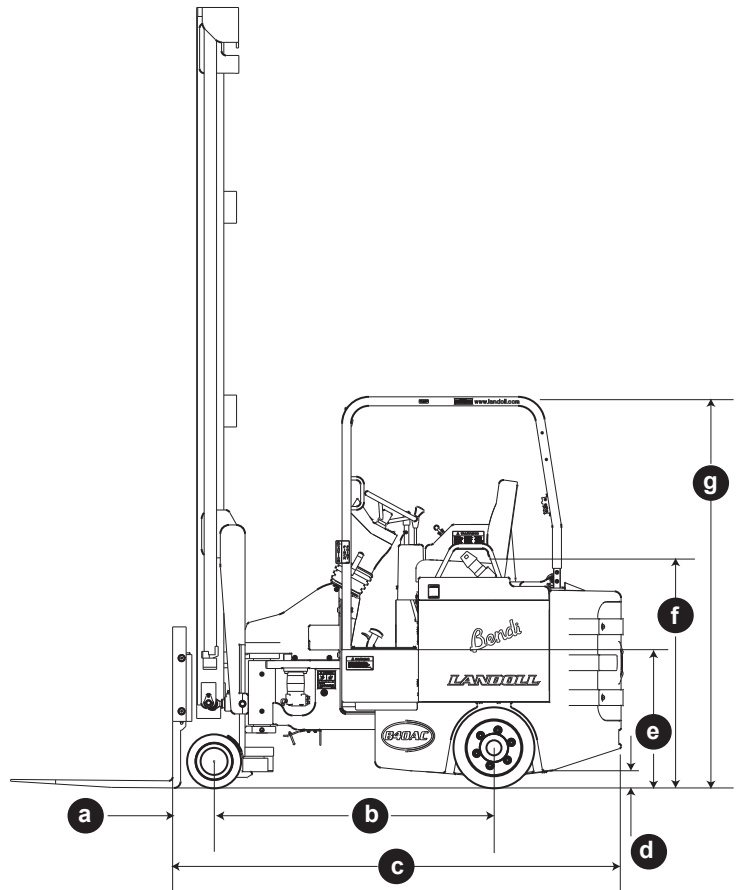

www.landoll.com/mhp

1900 North Street | Marysville, KS 66508 | (800) 428-5655



Intertek



ANAB
A.C. R. 12.11.12
MANUFACTURING EXCELLENCE
CERTIFICATION BODY



YOUR INDUSTRY CONNECTION
MHEDA



The Resource for Warehouse Logistics



International Association of Refrigerated Warehouses