

DREXEL[®]

SL60 / SL80

SWINGMAST[®] VNA/Sideload
Electric Multi-Purpose
6,000 lb. (2,722kg) Capacity
8,000 lb. (3,629kg) Capacity

STANDARD FEATURES

- Four-Wheel Configuration - 6,000 lb. (2,722kg) Capacity
- 72 Volt Electrical System
- Curtis SEPEX Dual Traction Motor Controllers
- Curtis Series Hydraulic Motor Controller
- Battery Discharge Indicator with Lift Interrupt
- Hydrostatic Power Steering
- 30" (762mm) of Shift-Includes 3" (76mm) of Reach
- 40" (1,016mm) Long Shank Forks with Standard Taper
- Poly Drive and Steer Tires
- 42" (1066mm) High Load Backrest
- Type E Construction
- Anderson SBX350 Green Connector
- Seat Belt (Retractable)
- Horizontal Fork Indicator, Overhead Guard
- Key Switch, Hand Parking Brake and Hour Meter
- Meets ANSI B56.1

OPTIONAL FEATURES

- EE Construction (Includes Battery Side Cover)
- Non-Standard Fork Lengths
- Dual Overhead Guard Mounted LED Headlights
- Dual Rear Safety LED Light Bars
- Safety Flashing LED Light
- Backup Alarm - Beeping Tone ("smart" dB adjusting)
- Fire Extinguisher - OHG Post Mounted
- Cold Storage Conditioning to -22° F (-30° C)
- Roller Slide-Out Battery Tray
- Lazer Fork Height Indicator
- Fork Positioner
- Keyless Key Pad On-Off
- Long Load Handling Package
- Auxiliary Hydraulics
- Overload Sensor with Alarm

LANDOLL CORPORATION
www.landoll.com/mhp | 800-428-5655



TECHNICAL DATA

MODEL			SL60	SL80
Capacity		lbs/kg	6,000 / 2,722	8,000 / 3,629
Load Center		in/mm	24 / 600	24 / 600
Power Source			Battery, electric	Battery, Electric
Weight with Battery		lbs/kg	18,700 / 8,500	20,900 / 9,500
Travel Speed	Loaded	mph/kph	6.9 / 11.1	6.9 / 11.1
	Unloaded	mph/kph	7.7 / 12.3	7.7 / 12.3
Lift Speed	Loaded	fpm/mpm	55 / 16.7	55 / 16.7
	Unloaded	fpm/mpm	70 / 21.3	70 / 21.3
Lower Speed	Loaded	fpm/mpm	95 / 28.9	95 / 28.9
	Unloaded	fpm/mpm	60 / 18.2	60 / 18.2
Mast Tilt	Forward / Backward	deg	3 / 4	3 / 4
Lost Load Center	A with Triple Mast	in/mm	24 / 607	24 / 607
Wheelbase	B	in/mm	56 / 1,422	56 / 1,422
Overall Length to Face of Forks	C with Triple Mast	in/mm	105 / 2,667	109 / 2,769
Underclearance	D	in/mm	4 / 102	4 / 102
Cab Floor Height	E	in/mm	32 / 889	32 / 889
Seat Height	F	in/mm	52 / 1,321	52 / 1,321
Overhead Guard Height	G	in/mm	90 / 2,286	90 / 2,286
Chassis Width	H	in/mm	52 / 1,321	56 / 1,422
Mast Shift	I	in/mm	30 / 762	30 / 762
Side Reach	J	in/mm	3 / 76	3 / 76
Side Deck Height	K	in/mm	52 / 1,321	52 / 1,321
Side Deck Width	L	in/mm	24 / 610	27 / 686
Fork Carriage Width	M	in/mm	41 / 1,041	41 / 1,041
Turning Radius	N	in/mm	93.5 / 2,375	96.5 / 2,451
Fork Length		in/mm	40 / 1,016	40 / 1,016
Gradeability	Loaded	%	15	15
Lift Motor Rating		kWh	17.6	17.6
Steer Motor Rating		kWh	6.5	6.5
Drive Motor Rating	2 Each	kWh	7.5 x 2	7.5 x 2
Wheel Sizes	Front (2 Each)	in/mm	20x9 / 508x229	20x9 / 508x229
	Rear (2 Each)	in/mm	16.25x7 / 413x178	16.25x7 / 413x178
Battery Recommended	Electric 72 Volt	kWh	53-55	53-55
Minimum Battery Weight		lbs/kg	4,300 / 1,955	4,300 / 1,955

DREXEL® SL60 SL80

Electric Multi-Purpose VNA
and Sideloader
SwingMast® Forklift Truck

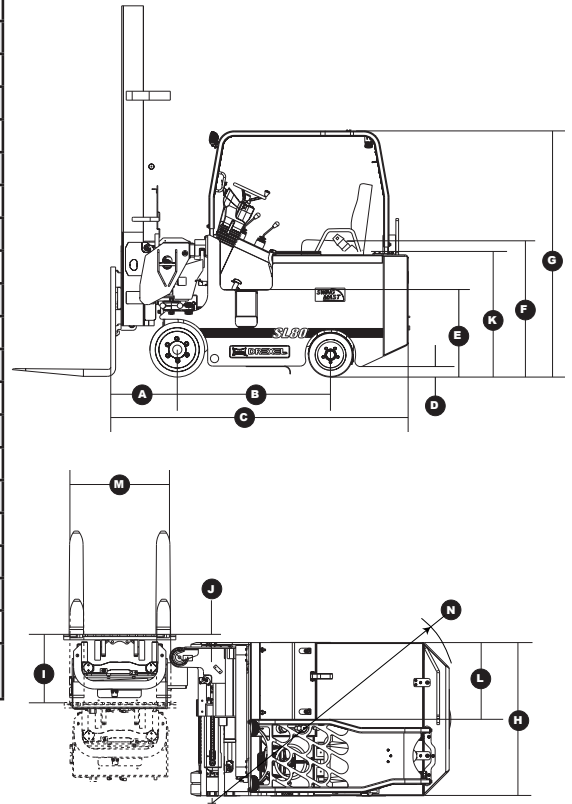

MAST DIMENSIONS

LIFT HEIGHT		LOWERED HEIGHT		FREE LIFT*	
Inches	Meters	Inches	Meters	Inches	Meters
141	3.58	83	2.11	41	1.04
159	4.04	89	2.26	47	1.19
177	4.50	95	2.41	53	1.35
197	5.00	103	2.62	61	1.55
221	5.61	113	2.87	71	1.80
245	6.22	125	3.17	83	2.11
259	6.58	131	3.33	89	2.26
289	7.34	141	3.58	99	2.51

* Free Lift Based on 42" (1067mm) High Load Backrest

RECOMMENDED BATTERY

BATTERY DESIGNATION: 36-85-19, 72 VOLT, 765 AHC (6 HOUR RATE)

Battery Weight Min: 4,300 lbs. (1955 kg) - Max. 4,700 lbs. (2136 kg)

Leads: Position D, 36" Long, with SBX 350 Amp Green *Connector

Nominal Size: 38.38" x 44.38" x 22.62" (98 x 113 x 58 cm)

Compartment Size: 39.625" x 45" x 23.5" (100 x 114 x 60 cm)

*SBX Connector must have 48 Volt 20 Amp Auxiliary Circuit

The specifications contained in this spec sheet are subject to change at any time without notice. Actual dimensions and performance data given herein may vary due to manufacturing tolerances.



www.landoll.com/mhp

DREXEL

1900 North Street | Marysville, KS 66508 | (800) 428-5655

SL60/SL80-1017



Intertek

