



**STRONG PARTNERS.
TOUGH TRUCKS.™**

END RIDER SERIES

B60ZAC2 , B60-80ZHD2

WWW.HYSTER.COM

THE HYSTER® END RIDER

The speed of technological advancement is exponential. As a culture we're introduced to new and fantastic innovations in increasingly shorter intervals. Materials handling technology is no exception. Just how good is your ability to predict what you'll need in the future? Our answer – you don't have to. At Hyster Company, we integrate innovative technologies into our lift trucks so you can be better prepared for the future.

The Hyster End Rider Series embodies the future of materials handling. Available in single, double or triple pallet 6,000 and 8,000 lb. capacity, these revolutionary pallet trucks are engineered to take on demanding applications in a multitude of operating conditions. Armed with forward-thinking, innovative features, the Hyster End Rider leads the way.



B60ZAC2

B60-80ZHD2

A man in a dark polo shirt and jeans is operating a Hyster pallet jack in a warehouse. The pallet jack is carrying a large stack of cardboard boxes wrapped in clear plastic. The man is looking back over his shoulder towards the camera. The background shows industrial shelving and a bright light source.

**JUST HOW GOOD
IS YOUR ABILITY
TO PREDICT WHAT
YOU'LL NEED IN
THE FUTURE?**

**OUR ANSWER –
YOU DON'T HAVE TO.**

THE WORLD IS CHANGING FAST ...

Can your current materials handling equipment keep up with an ever-changing, fast-paced, demanding environment?

We put ourselves in your application, talked to you and your operators, and tested our trucks against competitive models. After thorough research and planning, Hyster has gone above and beyond what you've typically seen in a pallet truck. We've designed the end rider with innovative and industry-exclusive features that will lead the way.



PRECISION PICK

Precision pick allows you to precisely place the truck where you want it, controlling the speed and coast functions in both directions (forward and reverse) with the simple press of a button.



... ARE YOU READY?



EXTENDED OPERATOR PLATFORM

With 30% more usable foot space and 30% less shock and vibration, our optional extended operator platform may be suitable for certain applications.



ULTRA CUSHION

The optional Ultra Cushion is designed from military-grade materials to reduce shock and vibration up to 30%. The raised pattern of the floor mat is designed to maximize traction, and strategically placed drain holes are beneficial for wash-down applications.



LED PLATFORM LIGHTS

Optional LED platform lights help give operators and pedestrians a heightened awareness of the truck location and platform edges in particular applications. Recessed within the bumper, the lights are encased in solid cast urethane for durability.



LED FORK LIGHTS

Optional fork lights offer in-trailer illumination, assists pedestrian awareness, can reduce product damage and helps increase your bottom line.

> **SETTING THE BAR FOR WAREHOUSE APPLICATIONS**

With the Hyster® End Rider Series, you'll be armed with intelligently designed technology to help make your operation run faster, leaner and more efficient in almost any application.

SHIFT ASSIST

Shift Assist is a set of software features that allows an operator to better use the truck to improve efficiency and increase productivity - driven off of the shift button, just like on your keyboard - it's a shortcut to increased functionality to help you get more out of every shift.



INTELLIGENT LIFT/LOWER

Automatically fully raises/lowers forks with one touch. Shaves seconds off picks by enabling the operator to focus on the next task while the truck completes fully lifting/lowering.



INTELLIGENT ACCELERATION

Two distinct acceleration profiles based on application, load and task. Saves 1-4 seconds per movement by accessing the faster profile before loads are too high.



INTELLIGENT SLOW DOWN™

Automatically reduces speed in cornering for improved stability. Provides enhanced load stability and operator control, decreasing risk of product/load damage.



INTELLIGENT CRUISE

Cruise control system that allows the operator to set speed and relax wrist on long runs. Minimizes wrist/hand stress, allowing operator to focus on task at hand.



PRECISION PICK

Positions the operator farther away from the truck while picking to reduce the chances of incidental contact. One-touch, precise control of travel can shave seconds off picks and reduce steps.



HYSTER TRACKER

Provides a scalable solution for fleets, from monitoring truck utilization to limiting operator access. Hyster Tracker allows you to track your fleet at your fingertips.



MULTIFUNCTION TOUCH FULL-COLOR DISPLAY

Access functionality, software, diagnostic codes and similar interfaces.



EXTENDED SHIFT

Balances battery and shift life, allowing the truck to run longer between battery changes.



Did you know that the ergonomics of your materials handling equipment could have a direct effect on your company's bottom line? Workplace ergonomics is nothing new – it was a hot topic even in the last century. So you already know that workplace ergonomics can positively benefit your employees.

STEER TILLER HANDLE

Soft touch, anti-slip texture allows firm grip even when wearing gloves. Large, centrally located horn, lift, and lower buttons are easily accessible from either side.



CURVED STEER TILLER

Integrated scallop provides a comfortable interface for operators to position their leg when steering the truck with their body.



CUSHIONED PLATFORM

Ample space on the front of the platform provides a strong foundation. The raised pattern of the cushion maximizes operator traction. Standard cushion provides 7% less shock and vibration than leading competitor.



At Hyster, we've intentionally designed 6 points of operator contact, not just 5 like competitive models. Now your operators' can feel more comfortable and secure all shift long.

6 POINTS OF CONTACT



REAR HAND RAIL

Quickly and efficiently pick a pallet using a single hand position. Simultaneously access dual horn buttons, loft/lower or high speed button.

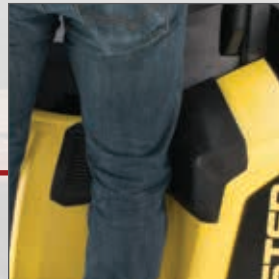

KNEE PAD

Contoured with venting and a unique waffle pattern to provide comfort and flexibility.



FOOT WELL

Enter or exit easily with extra room provided by the foot well. Located under the motor cover, the foot well helps give the operator extra usable foot space.

> DURABLE COMPONENTS. SIMPLIFIED SERVICEABILITY.

No matter your role, your reputation is always on the line. Day in and day out – you've got to keep things moving. How can you reduce the chances of that dreaded “my equipment is down” moment?

With reduced service times and increased service intervals, **this truck can be serviced faster and as much as 50% less often**, meaning less time out of service and more time moving product.

Springless, heavy duty casters resist damage from dock plates and are adjusted from the top of the truck, significantly reducing maintenance time.

Key lift linkage components are cast steel for maximum strength.

Frame and forks connect for reduced twist and increased torsional stiffness.

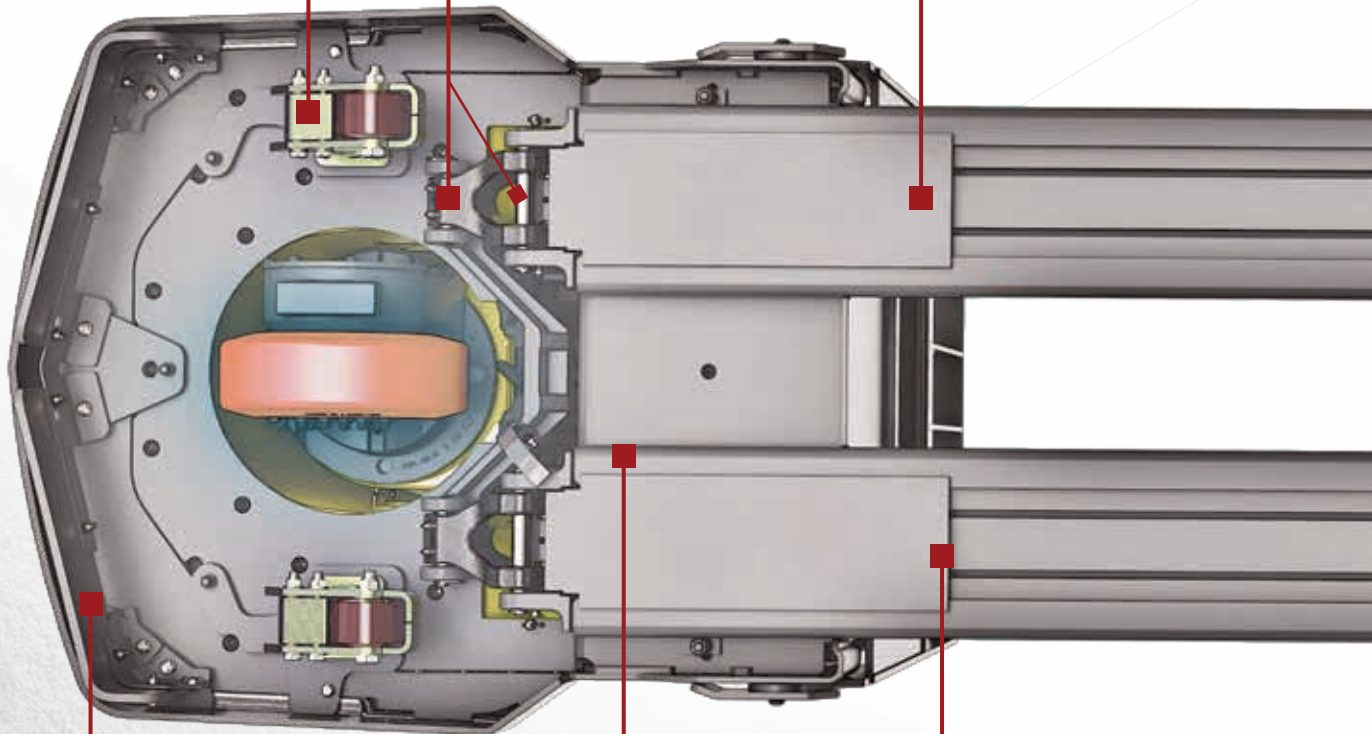

Enhanced frame has more metal in all the right places for greater strength and steadier load handling.

Forks' connection with the battery box reduces strain on the undercarriage and linkage.

Reinforced undercarriage is protected against impacts.



Standard fork tip with entry skid bar
(shown with optional extended fork tip)



Standard fork tip with entry rollers
(shown with optional extended fork tip)

Oversized pull rods tie linkage together for smooth lifting and lowering.

Increased exit roller size reduces pallets' tendency to drag.

Fork tips are specifically designed for smooth pallet entry. Increasing fork-pallet interlocking pressure by 500% allows for successful pallet exit on the first try.
(extended fork tips shown)

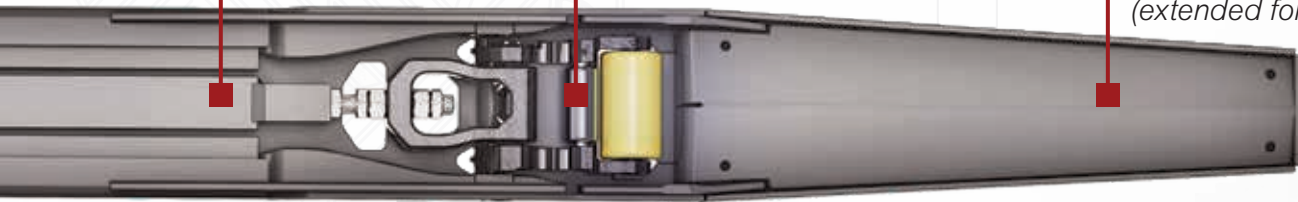

A 50% increase in steel on standard forks and 75% increase on double pallet forks give this truck strength to lift the heaviest of loads. Single-piece casting reduces stress on the risers.

Lubrication points can be accessed with the truck on the floor and the battery in the battery box.



Learn more about Hyster® linkage, frame and forks.

INNOVATIVE TRUCKS ENGINEERED TO MEET THE MOST DEMANDING APPLICATIONS

For nearly 90 years, Hyster has conquered the world's most demanding applications. In the 1920s Hyster started as a manufacturer of lifting machines used in the rigorous logging industry of the United States' Pacific Northwest. A few years later the first forklift trucks were invented and the Hyster brand quickly gained its reputation for rugged quality. Hyster® lift trucks are designed to lower your cost of operations. Every truck we make — whether powered by gasoline, LPG, diesel, electric, CNG, lithium-ion or hydrogen fuel cells — is purpose-built to excel in its application. Every truck is also backed by an unmatched network of specialists.



Dealer Network — Our Dealer Network can offer the expertise of fleet managers, parts suppliers, capital procurement specialists and trainers. Carefully chosen dealers fully understand customer applications, assist in selecting the right lift truck and provide fast, reliable support.



Hyster Fleet Services — Even if you operate other brands, we can manage your maintenance and replacement plan. We can offer complete fleet analysis, fleet history summary and a cost-effective proposal for replacement and scheduled maintenance.



Parts — With genuine Hyster® replacement parts and UNISOURCE™ parts for all makes of lift trucks, we are your one-stop source for lift truck parts. In fact, we offer more than 7 million part number crosses for most brands of materials handling and other in-plant mobile equipment.



Rental Products — When leasing or buying isn't a practical option, we have access to more than 14,000 units for short- and long-term rental. We'll help you maintain output in a cost-effective manner.



Hyster Capital — We can arrange solutions for special financing requirements, taking the difficulties out of buying the equipment you need. Whether you purchase or lease a new or used lift truck, Hyster Capital offers superior service and competitive rates.



Special Products Engineering Department (SPED) — Different materials require different handling. That's why we can work with you to customize your lift trucks. From strobe lights to specially made forks, SPED has the tools to help you get the job done right.



Operator Training — Proper education in operating lift trucks minimizes the risk of injuries due to accidents while increasing productivity. Hyster offers OSHA-compliant materials that support the training of qualified operators.



Service — Your local Hyster® dealer offers a flexible, customized and comprehensive maintenance plan based on each lift truck's operation environment. Hyster service programs offer scheduled inspections and maintenance, along with quick, responsive service dispatched to your location.



Hyster Company
P.O. Box 7006
Greenville, North Carolina
27835-7006
Part No. ENDRIDER/B
12/2018 Litho in U.S.A.

Visit us online at www.hyster.com or call us at **1-800-HYSTER-1**.

Hyster,  and STRONG PARTNERS. TOUGH TRUCKS. are registered trademarks in the United States and certain other jurisdictions. Hyster products are subject to change without notice.

Trucks may be shown with optional equipment. © 2018 Hyster Company. All rights reserved.